

NMI V Fitting: User Instruction Leaflet

To be operated by trained personnel only

Securing the V Fitting

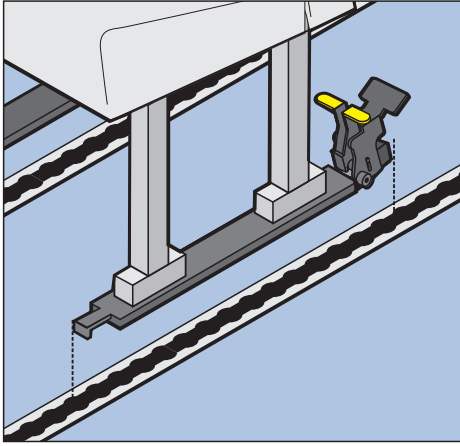

Line V Fitting with track

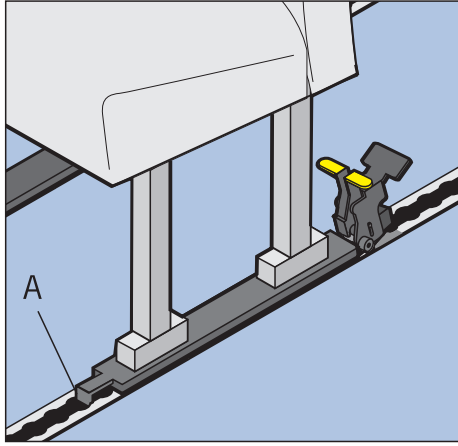

First drop front 'L' bracket A into a hole in the track and then drop fitting into the track so they are flat

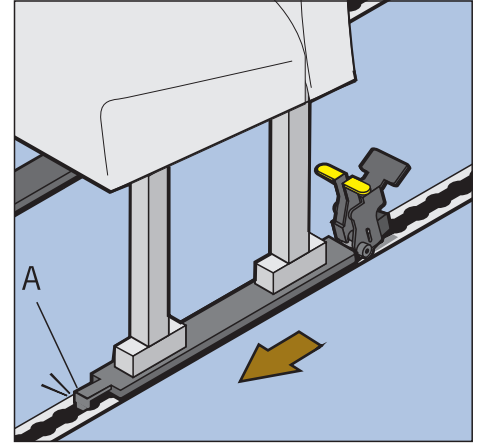

Push seat forward until A is at the front of the track hole

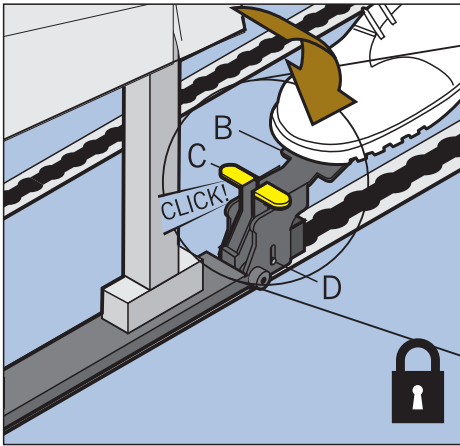

Push down the foot pedal clamp B. Yellow drop lock C will engage against the main body. Check D is against the bottom of the slot. (See close up picture) The V Fitting is now locked

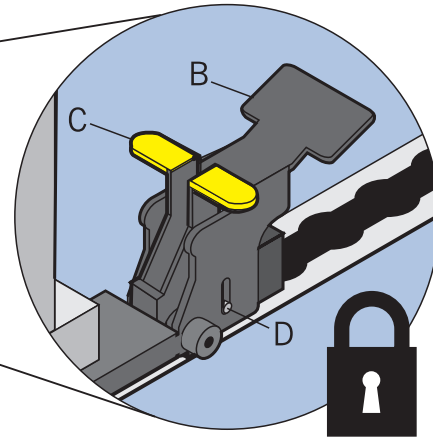

If the fitting is not in the correct position the pedal clamp B will not clamp and the safety lock C will not be in the lowered position

Removing the V Fitting

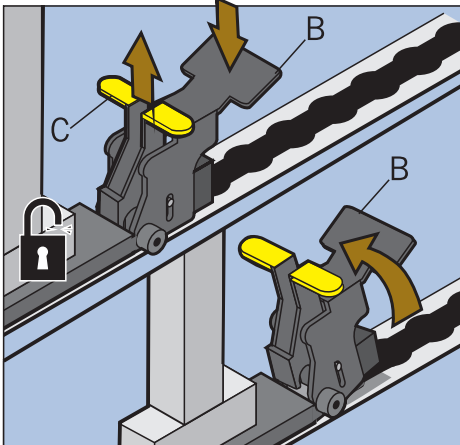

Apply pressure down on foot clamp B and lift up yellow drop lock C. Then while holding C up lift up pedal clamp B

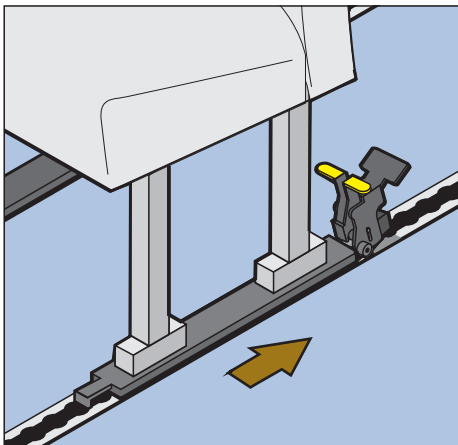

Slide the fitting backwards as far as it will go

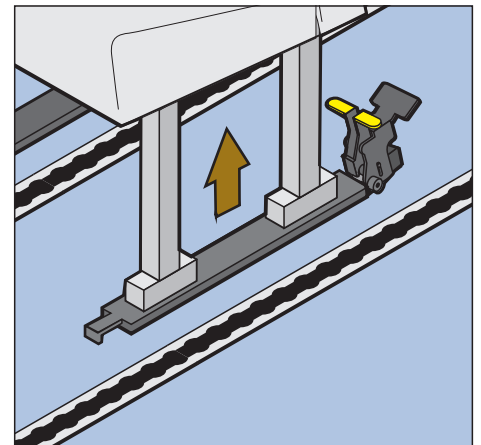

Lift the V Fitting from the tracking