



Quick Instruction Sheets

RIPS DRUM PEDAL MECHANISM:

TO LOCK

Lift the seat back webbing off the Velcro to allow the yellow bar to drop down onto the outer drum ratchets.

Using both hands grip the yellow part in the middle of the pedal and push it forwards and down so it engages the middle drum ratchets.

Now tread on the pedal to winch in the webbing belts.

TO UNLOCK

Tread on the foot pedal and at the same time pull the seat back webbing up so as to lift the yellow bar off the outer drum ratchets. Then re - stick the webbing to the Velcro to keep the bar up.

Using both hands grip the yellow part in the middle of the pedal and pull back and up so that it disengages from the middle drum ratchets and releases the webbing belts.

Instruction Sheets

RIPS/R/D/4: Removable Rip Seat with 4 Millennium Fittings

Before Locking in Tracking

1. Before locking the seat into tracking, tilt the seat backward and wheel the seat into correct position.
2. Unlock Millennium Fittings by moving the red safety lock nut along the slot from position A into position B. Whilst holding the nut in position B pull back the red handle (see Fig 1). The Millennium Fitting is now in the unlocked position ready for fitting.
3. Lift and turn the grey plunger fittings which are at the rear of the base unit in front of the wheels.

To Lock in Tracking

1. Position front stud into tracking in the desired position so that the base plate sits flat on the track.
2. Turn the plungers and move the unit slightly backwards and forwards so that the plungers drop into the holes in the track.
3. Finally lock the RIPS seat fitting into the track by pushing the red handle on the Millennium Fitting forward to its furthest point (see Fig 2). The red safety lock nut will automatically drop into position A in the slot. Repeat on all four fittings. The RIPS unit is now fixed and ready for use.

To Unlock in Tracking

1. To remove the unit from tracking reverse the operation from 3-1 making sure that the fixed front stud clears the lips of the track.

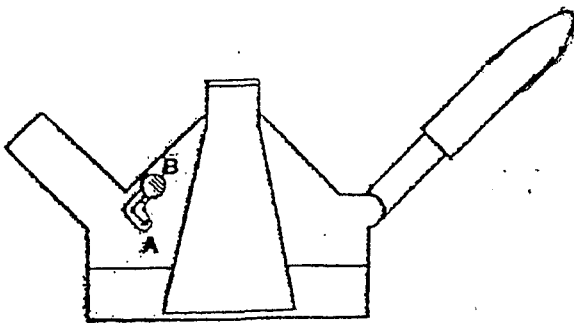

Fig 1 Unlocked

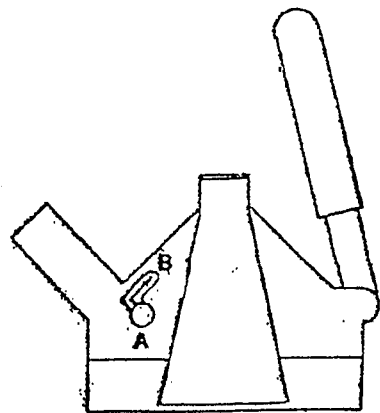

Fig 2 Locked



Instruction Sheets

To Convert from RIP Seat in Standard Position to Wheelchair Back Support

Step 1 Remove the Seat Cushion

Pull out plunger and lift yellow latches on both sides of the RIP base (see Fig 2). This will free the seat support brackets of the seat cushion. Remove the seat cushion from the base.

Step 2 Secure the Wheelchair

Depress foot pedal slightly and pull upwards on webbing strap hanging out of the seat back. (see Fig 3). This will disengage the webbing drum ratchet mechanism (see Fig 6). Then stick the webbing strap to the Velcro on the back of the seat.

Disengage the pedal ratchet (see Fig 4). To do this grasp the yellow dog's contoured sides with thumb and forefinger. Slide the yellow dog backwards and then using the other hand push dog upwards thus engaging A behind the 'Lip' B. The yellow dog is now no longer touching the middle ratchet.

Take karabiners (see Fig 5) which are situated between the legs and hook onto the back of the wheelchairs tubular frame.

Remove the webbing off the velcro on the seat back and feed the webbing back into the seat back to re-engage the webbing drum ratchet mechanism (see Fig 3).

Then push the yellow pedal ratchet forward and then down so that it is touching the middle ratchet.

Fit adapter beam to base (if required). (See Adapter Beam instructions).

Tighten the black webbing with karabiners by pumping the foot pedal until the wheelchair is firmly back against the back support. Engage the wheelchair brakes.

Step 3 Securing the Passenger

Secure the passenger using the two shoulder straps fastening one at a time diagonally across the passenger shoulders fixing down on the lower buckles. Please use all age adjusters provided. (See Instruction sheets on Dual Position Stalk Fixings).

Step 4 Storing the Cushion

With the underside of the cushion facing the back support, locate the protruding part of the cushion support arms into the corresponding brackets on the back of the seat base. Lift the yellow rear cushion latch positioned at the side of the base on to the cushion frame pin.

The RIPS and Wheelchair Passenger are now ready for Transit



Instruction Sheets

To Unlock the Wheelchair

- Step 1 Remove the passenger restraint seat belts so the occupant is free.
- Step 2 Remove the seat cushion from its stored position at the back of the seat back to gain access to the foot pedal. To do this lift the yellow cushion latch off the frame pin.
- Step 3 Depress the foot pedal below its locked position and at the same time pull the red strap protruding from the rear of the back support to disengage the webbing drum ratchet mechanism. (see Fig 3).
- Step 4 Disengage the pedal ratchet (see Fig 4). To do this grasp the yellow dog's contoured sides with the thumb and forefinger. Slide the yellow dog backwards and then using the other hand push the dog upwards thus engaging corner A behind the 'Lip' labeled B. The pedal ratchet is now disengaged.
- Step 5 Push the wheelchair away from the back support and unlock the karabiners (see Fig 5). The wheelchair is now free.

The Wheelchair & Passenger are now disengaged from the RIPS.

Drum Pedal

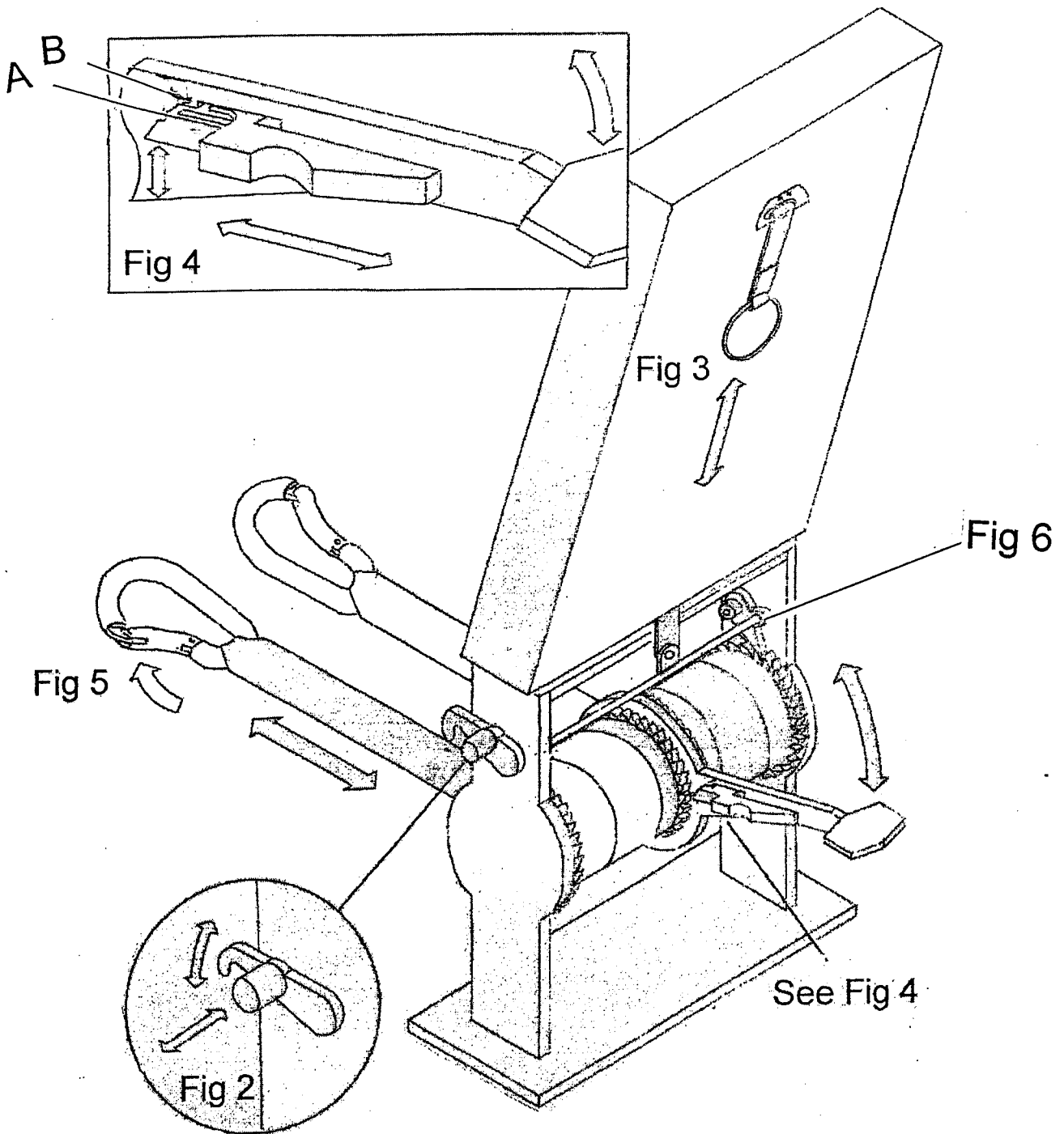

Instruction Sheets

Dual Position Stalk Fixings

When in use as a passenger seat

In order to provide a more secure wheelchair passenger restraint system, additional stalk fittings have been fitted to the RIPS base. When the RIPS is being used as a seat, the passenger should use the upper stalks positioned at the bottom of the back support.

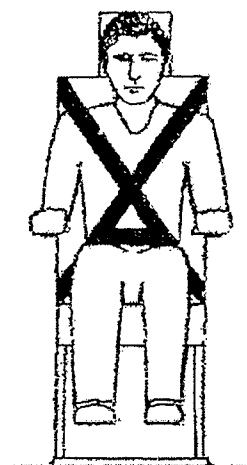
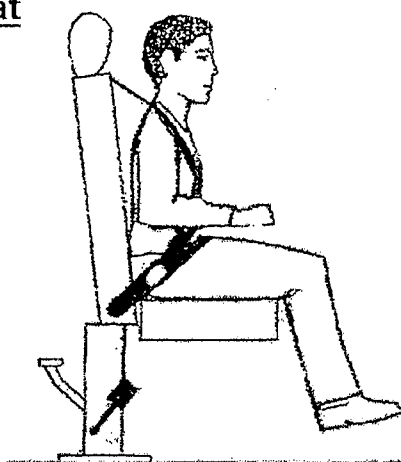

See diagram

When in Use as a Wheelchair Docking Station

When the RIPS is being used as a wheelchair docking station, the lower stalks found on the base should be used as they offer more secure fastening of the wheelchair passenger.

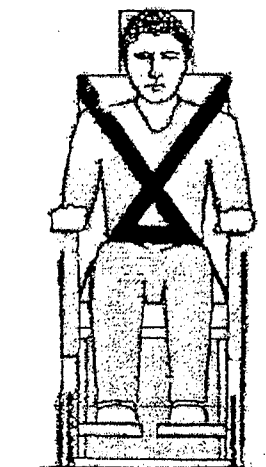
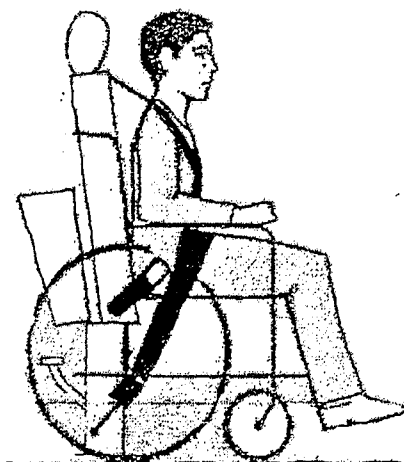

See diagram

Instruction Sheets

Adapter Beam

All RI P's now come equipped with an Adapter Beam 'R'. Before ratcheting back the wheelchair locate the adaptor beam into the location points that the seat cushion frame originally located in. Once fitted re-engage the yellow retaining hooks 'A'.

Note: Ensure that the plunger on the hook engages in the hole on the side of the plate.

Once the adaptor beam has been fitted the wheelchair can now be ratcheted back. Before finally tightening the wheelchair ensure that the wheelchair frame is located against the two adjustable bars 'S'. Once located the wheelchair can be fully ratcheted back and secured.

