

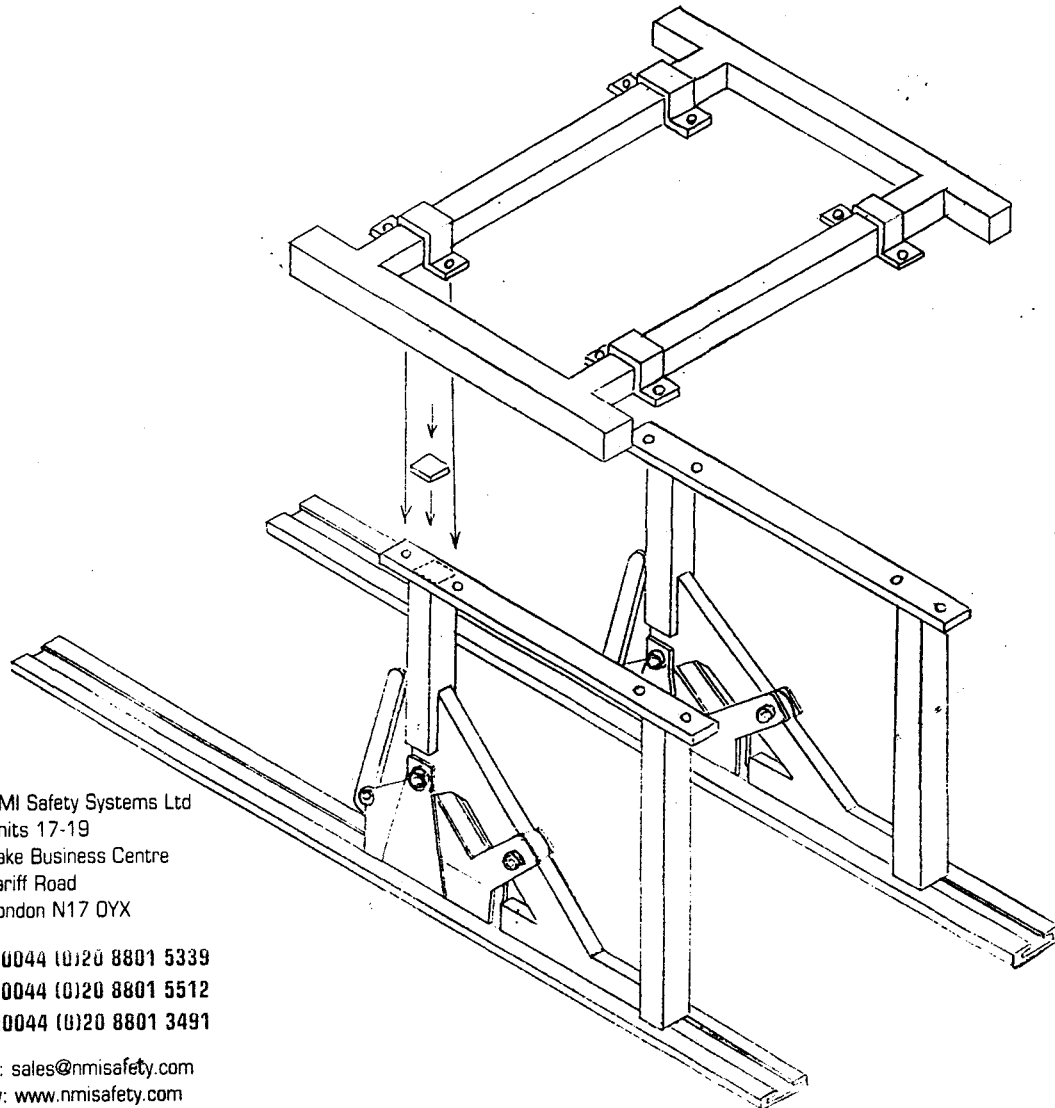

## **SafetySystems**

Now that you have started to purchase and fit the NMI Millennium System we would like to take this opportunity in the light of our experience to offer some advice on the fitting of the Millennium seat fitting to the seat.

Thank you for your co-operation.



### **SEAT TO LEG/ASSEMBLY INSTRUCTIONS FOR THE NMI MILLENNIUM SYSTEM**

- 1.) Place the seat fittings/legs into the track ensuring that the track is as flat and level as possible.
- 2.) Lock the seat fitting into the track.
- 3.) Place the seat on top of the seat legs. If the seat frame rocks on the top of the seat legs, place a shim under the highest point between the seat frame and the top of the seat legs indicated by the arrows (See diagram). This will ensure that the seat fittings are parallel with the seat frame. Once shimmed, tighten the front two and the rear two top hat M8 bolts, now pinch tight.
- 4.) Once the outside bolts are tightened, release the seat fitting from the track and it should lift it in and out of the track with no interference and be able to slide easily.
- 5.) Once the seat and the legs are correctly positioned tighten the four inside M8 bolts.
- 6.) Once final bolt tightening has been completed test in track again.

NMI Safety Systems Ltd  
Units 17-19  
Lake Business Centre  
Tarriff Road  
London N17 0YX

T:0044 (0)20 8801 5339  
T:0044 (0)20 8801 5512  
F:0044 (0)20 8801 3491

e: sales@nmisafety.com  
w: www.nmisafety.com



INVESTOR IN PEOPLE